

WIND CLEANER



TECHNICAL FEATURES

- Cleaning chamber fitted with: adjustable feeding flaps - cleaning sections - exhaust air recovery - rotary valve for the discharge of heavy pollutants
- Sifting system based on sequentially differentiated fluidization speeds
- Fan
- Discharge cyclone with rotary valve for clean particles
- Piping with flaps to adjust the fluidizing speed.

BENEFITS

- Removal of heavy pollutants out of recycled fines, wet and dry, e.g.: minerals such as sand, stones, metals, etc. - atypical pollutants such as ABS, plastics, rubber, glass, laminates, etc.
- Highly reliable and flexible adjustment
- Very high cleaning efficiency
- Improved panel machinability
- Low cost, low energy consumption, easy maintenance.

CARATTERISTICHE TECNICHE

- Camera di pulizia equipaggiata di: - deviatori di carico facilmente regolabili - pulizia a sezioni - recupero dell'aria esausta - valvola rotante per lo scarico degli inquinanti pesanti
- Sistema di separazione basato sulla sequenziale differenziazione della velocità fluidificativa
- Ventilatore
- Materiale pulito ciclonato e scaricato tramite una valvola stellare
- Tubazioni con deviatori facilmente regolabili per fluidificare il flusso dell'aria.

BENEFICI

- Rimozione degli inquinanti pesanti presenti nel materiale fine del riciclato, secco o umido
- Altamente affidabile grazie a regolazioni flessibili
- Elevata efficienza di pulizia
- Miglioramento della lavorabilità del pannello che si creerà
- Bassi costi di manutenzione
- Bassi consumi elettrici
- Facili manutenzioni.

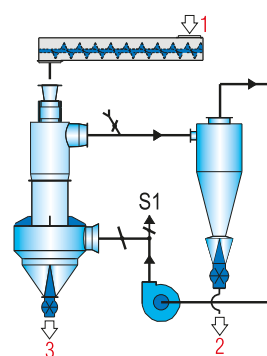
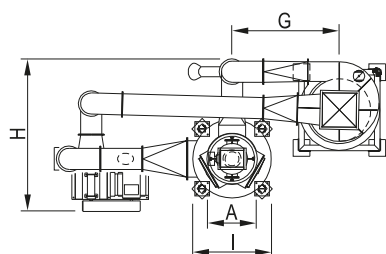
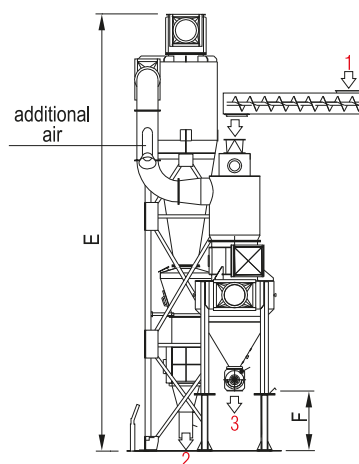
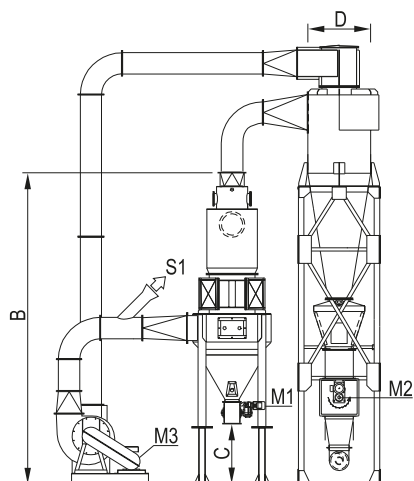

1 = INLET OF CONTAMINATED MATERIAL
 2 = ACCEPTS/CLEAN
 3 = REJECTS

M1 = ROTARY VALVE OUT
 M2 = ROTARY VALVE IN
 M3 = FAN DRIVE

MODEL	OVERALL DIMENSIONS mm								
	A	B	C	D	E	F	G*	H	I
WCL.15/10	600	5261	1407	800	5290	772	10000	1300	1100
WCL.15/25	600	5261	1407	800	5290	772	25000	1300	1100
WCL.30/10	900	6912	2270	1120	7148	1200	10000	2269	1400
WCL.30/25	900	6912	2270	1120	7148	1200	25000	2269	1400

*Maximum distance between centers

MODEL	CAPACITY TOP		INSTALLED POWER kW			EXHAUST AIR m ³ /h	WEIGHT APPROX. kg
	BULK m ³ /h	WET t/h	M1	M2	M3	S1	
WCL.15/10	7,5	1,5	1,5	1,5	11	1800	2800
WCL.15/25	7,5	1,5	1,5	1,5	15	1800	3800
WCL.30/10	15,0	3,0	1,5	1,5	15	3200	4600
WCL.30/25	15,0	3,0	1,5	1,5	30	3200	5550